

Aqabase[®] Rainwater Storage Tank

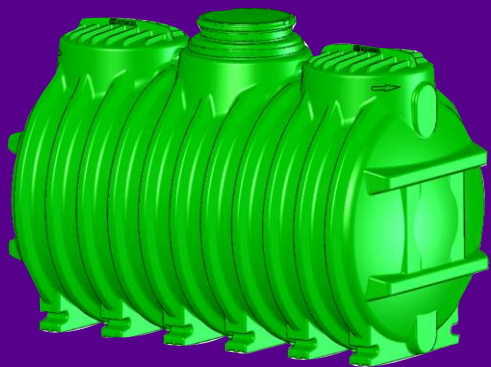

**NEW! Now with
up to 9000 liter
capacity!**

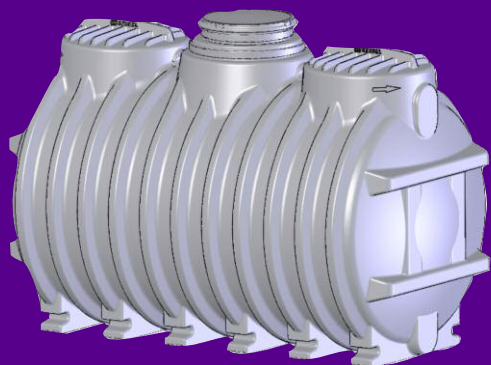

KESSEL Rainwater Storage Tank *Aqabase*®

Product Illustrations

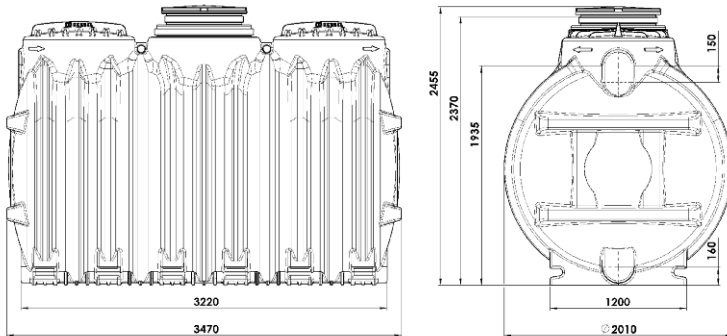
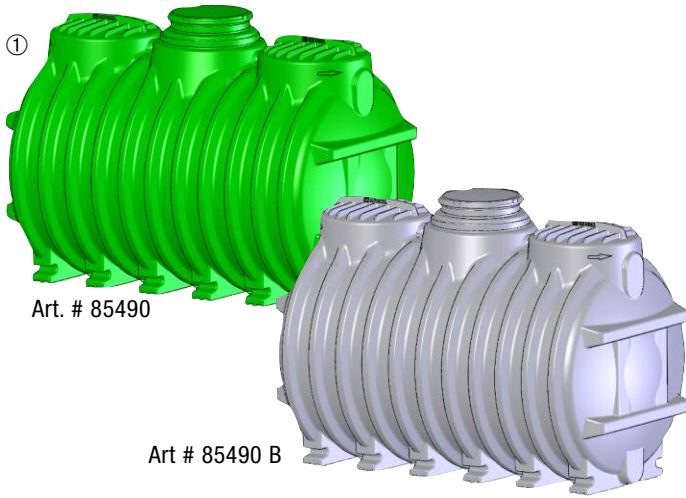

Product Description

KESSEL *Aqabase*® Rainwater Storage Tank *Aqabase*® for non-traffic areas

Polyethylene construction for underground installation.
Rainwater collection for lawn / garden watering.
With child proof safety cover. Twin Ø 110 gaskets for inlet / outlet.

Art # 85490

Complete system for

- Lawn / garden watering with **Art. # 85990.10** (①+②+③)
- Home / building use with **Art # 85990.13** (①+②+④+⑤)

KESSEL-*Aqabase*® Standard Rainwater Storage Tank

Polyethylene construction for underground installation.
Rainwater collection for lawn / garden watering.
With child proof safety cover. Twin Ø 110 gaskets for inlet / outlet.

Art. # 85490 B

KESSEL *Aqabase*® Komfort Rainwater Storage Tank for traffic areas

Polyethylene construction for underground installation.
Installation depth from mm to mm.
Rainwater collection for garden or home use.
With vertically adjustable upper section.

Art.Nr. 85490/80 B

Accessories



System 400
Rainwater filter for
underground
installation

Art # 85 323/120A

Load Class A
(1.5 ton)

Submersible
garden pump
Art. # 85 007

Intake filter
(floating)
Art # 85 051

Aqabull® Rainwater
Pumping System
With **Aqatronic® S**
control unit
Art # 85 101
With **Aqatronic® K**
control unit
Art # 85 201

Aqadive® Rainwater
Pumping System
with **Aqatronic® S**
control unit
Art # 85 601
with **Aqatronic® S**
control unit
Art # 85 801

garden pump
Self priming
Art # 85 006



www.kessel.de